



## *Installation Instructions*

# ProcessLogix/ControlLogix System Redundancy Module

(catalog numbers 1757-SRM/A, 1757-SRM/B)

This document tells you how to install the ProcessLogix™/ControlLogix™ System Redundancy Module (1757-SRM) into the ProcessLogix or ControlLogix Redundant Chassis pair. Read these installation instructions completely before you install the 1757-SRM. The 1757-SRM Series B has a user relay, Series A does not. Both series can be upgraded to firmware revision 2.xx or downgraded to firmware revision 1.xx.

## Installation Requirements

Before you begin assembling the components of your redundant systems, make sure that all aspects of your redundant system components are identical. This means:

- Chassis and system setup of the primary and secondary (redundant) control chassis must be identical, with all modules in the exact same order (slot for slot), in identical-sized chassis.
- The firmware revision levels of all module partners must be compatible.

---

### ATTENTION



If the primary and secondary (redundant) system are **not** assembled in identically the same configuration, **and** are **not** comprised of components with compatible firmware revision levels, the 1757-SRM will be unable to qualify the secondary to the primary.

---

## Important User Information

Because of the variety of uses for the products described in this publication, those responsible for the application and use of this control equipment must satisfy themselves that all necessary steps have been taken to assure that each application and use meets all performance and safety requirements, including any applicable laws, regulations, codes and standards.

The illustrations, charts, sample programs and layout examples shown in this guide are intended solely for purposes of example. Since there are many variables and requirements associated with any particular installation, Allen-Bradley does not assume responsibility or liability (to include intellectual property liability) for actual use based upon the examples shown in this publication.

Allen-Bradley publication SGI-1.1, *Safety Guidelines for the Application, Installation and Maintenance of Solid-State Control* (available from your local Allen-Bradley office), describes some important differences between solid-state equipment and electromechanical devices that should be taken into consideration when applying products such as those described in this publication.

Reproduction of the contents of this copyrighted publication, in whole or part, without written permission of Rockwell Automation, is prohibited.

Throughout this manual we use notes to make you aware of safety considerations:

---

### ATTENTION



Identifies information about practices or circumstances that can lead to personal injury or death, property damage or economic loss.

---

Attention statements help you to:

- identify a hazard
- avoid a hazard
- recognize the consequences

### IMPORTANT

Identifies information that is critical for successful application and understanding of the product.

---

## Redundancy System Assembly Preview

Assembling the primary and secondary chassis for redundancy is the same as assembling any ProcessLogix or ControlLogix chassis, except in this instance you will be assembling two identical chassis.

### ATTENTION



If you are adding redundancy to an already operational ProcessLogix or ControlLogix system, power down your process to install the 1757-SRM and to designate the primary system.

You may also have to use RSNetworkx or Ntools to configure keeper information in the secondary CNB if the master keeper for ControlNet is in the primary chassis.

	Tasks:
<input type="checkbox"/>	<ul style="list-style-type: none"> <li>Place the primary and redundant module(s) in the same corresponding slot in their respective chassis. See page 3.</li> </ul> <p>For example, if you place a 1757-SRM in slot 3 (from the left) in the primary chassis, you must also place a 1757- SRM in slot 3 in the redundant chassis.</p> <ul style="list-style-type: none"> <li>Refer to the ProcessLogix or ControlLogix Controller Module Installation Instructions (supplied with the 1757 or 1756 modules) and ControlLogix ControlNet Bridge Installation Instructions, Publication 1756-5.32.</li> </ul>
<input type="checkbox"/>	<ul style="list-style-type: none"> <li>Install the cable between the primary and secondary modules according to the System Redundancy Module Cable Installation Instructions, Publication 1757-5.14. See Figure 1 on page 4.</li> </ul>
<input type="checkbox"/>	<ul style="list-style-type: none"> <li>If you are using the 1757-SRM/B with the user relay, wire to the separable block connector supplied and plug it into the relay's terminal. See Figure 2 on page 5.</li> </ul>
<input type="checkbox"/>	<ul style="list-style-type: none"> <li>Make sure that all firmware revision levels are compatible between primary and secondary module pairs. See page 6.</li> </ul>
<input type="checkbox"/>	<ul style="list-style-type: none"> <li>Power-up one of the chassis to designate the primary chassis, then power-up the secondary chassis and allow it to qualify and become synchronized with the primary chassis. See page 6.</li> </ul>

## Installing the 1757-SRM

The 1757-SRM can be installed in any slot of the chassis. However, the primary and secondary system must have the 1757-SRMs installed in the same chassis slot position.

1. Prior to installing the 1757-SRM into the rack, locate the module's fiber optic port and connect one end of the Redundancy Module cable to it. See Figure 1.

**Figure 1 Front View of SRM (door open) With Fiber Optic Cable and Port**

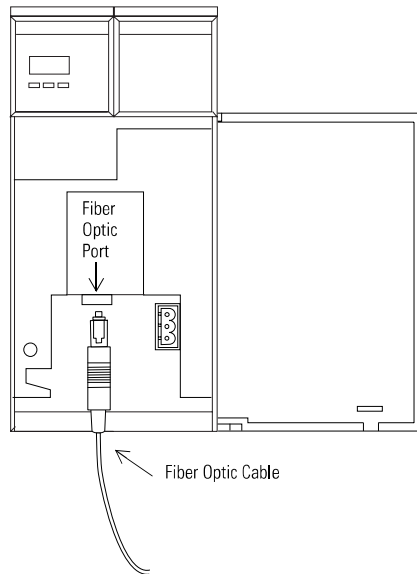

42792

2. Align the left module circuit board with the top and bottom guides in the chassis.
3. Slide the module into the chassis. Make sure the module properly connects to the chassis backplane.

**TIP**



When the module is flush with the other modules and the locking clips click into place, the module is installed.

To remove the module, push down on the locking clips at the top right and bottom left of each module. Slide the module out of the chassis.

4. Connect the optional field wiring to the separable terminal block connector and plug it into the user relay terminal. See Figure 2.

**Figure 2 Front View of SRM (door open) With Wiring, Connector, and Terminal.**

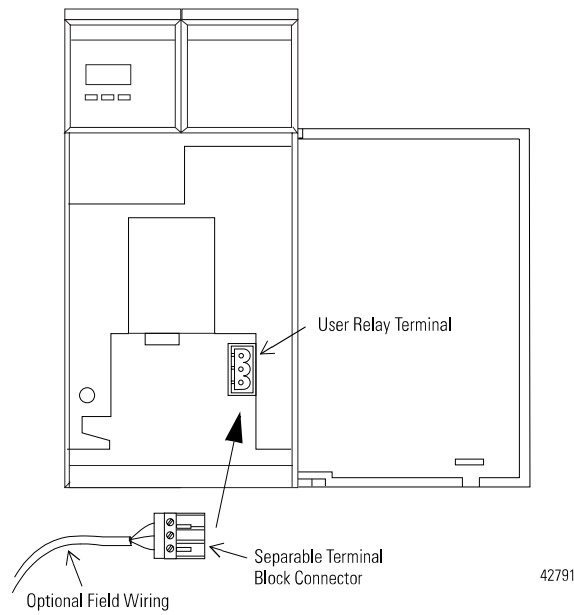

## Designate the Primary Chassis and Qualifying the System

Once you assemble the chassis, you must designate the primary chassis and then qualify the system to assure that all module pairs are at compatible firmware revision levels.

### ATTENTION



Initial power-up of the chassis is crucial to designating the primary and secondary chassis. Do not power up the chassis until you have read the instructions for designating the primary chassis.

## Designating the Primary Chassis

The chassis that is first powered up is automatically designated as the primary chassis. The 1757-SRM will display PRIM on the module's 4-character display to acknowledge that this chassis is the primary control chassis.

If both modules are powered up simultaneously, the module with the lowest serial number will be designated as the primary chassis and will display PRIM on the module's 4-character display. In addition, the PRI status light on the primary 1757-SRM will be ON. On the 1757-SRM/B, the normally open (NO) contacts of the user relay will be closed.

The secondary chassis is acknowledged by either DISQ or SYNC, depending on the state of the secondary chassis. In addition, the PRI status light on the secondary 1757-SRM will be OFF. On 1757-SRM/B, the NO contacts of the user relay will be open.

## Qualify the System

On initial start-up of the complete primary and secondary chassis, the redundant system will begin a qualification process. During qualification, the primary modules are compared with the secondary module partners to ensure that hardware and firmware are compatible.

If the 1757-SRM module displays:	Then:
<b>SYNC</b> after the chassis completes the power-up cycle and qualification	the chassis configuration and the firmware revision levels are compatible
<b>DISQ</b>	a problem exists:
<b>Important:</b> The secondary 1757-SRM will initially display DISQ until it completes the qualification process. This may take anywhere from 1 to 3 minutes.	<ul style="list-style-type: none"> <li>• with the chassis configuration <i>or</i></li> <li>• with incompatible firmware revision levels between primary and secondary module <i>or</i></li> <li>• if the CNB module partners' Keeper parameters are not the same</li> </ul>

### Flow Chart of Power-up of a Chassis with a Healthy 1757-SRM

See Page 12 for an explanation of the 4-character display status codes.

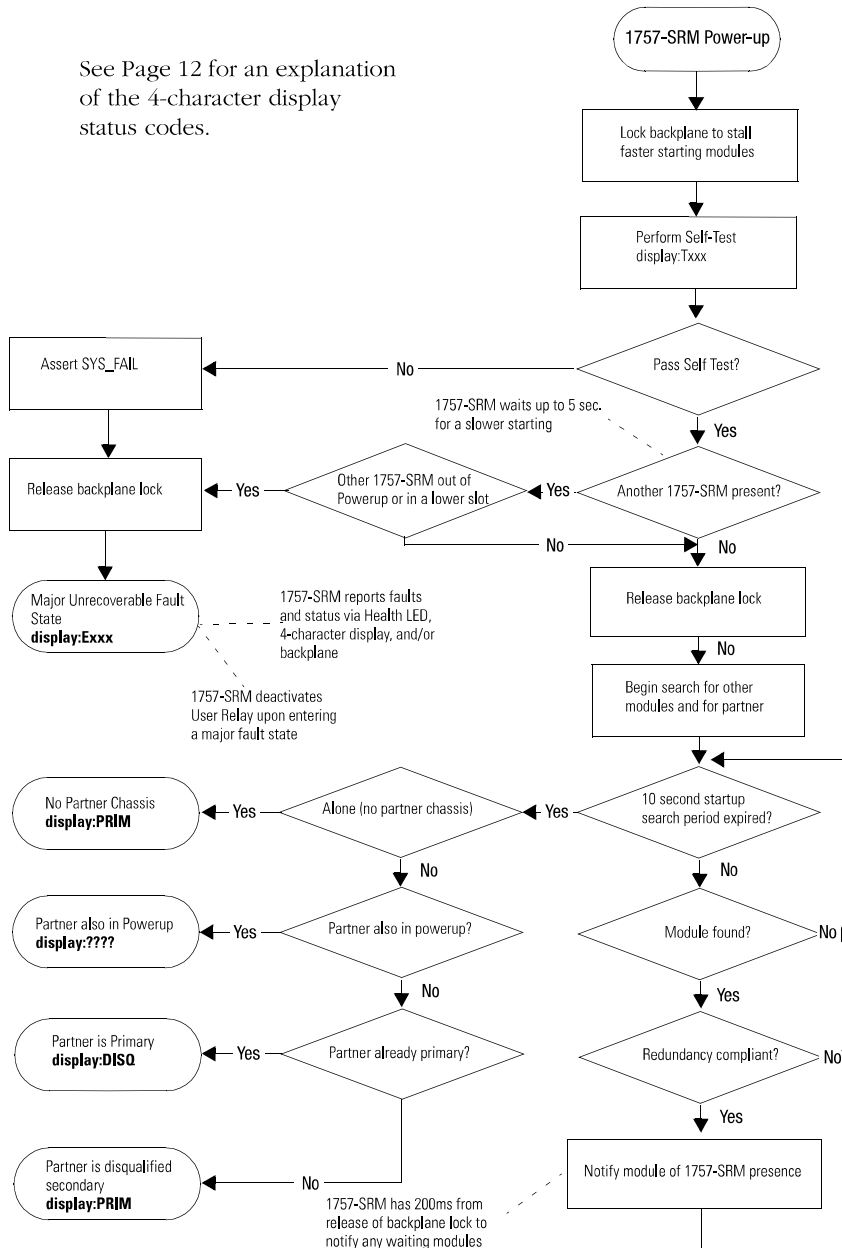

## User Relay Terminals for the 1757-SRM/B

The user relay is only available on the 1757-SRM/B module. The module will energize when it determines that it is in a primary control chassis. The relay has two terminals. The terminal plug is located on the right side of the 1757-SRM/B fiber optic cable. The functions of the terminals are:

### **Normally Open**

(NO) a relay contact that is not connected to the Common terminal when the relay is not energized, and is connected to the Common terminal when the relay is energized.

### **Common**

(COM) a common pole of the user relay that connects to the Normally Open contact when in the energized state as described above.

The user relay contacts are rated as follows:

Maximum Switching Voltage = 30VAC, 30VDC

Maximum Switching Current = 100MA

For an example of the user relay for Logix Controller serial port redirection, See Figure 3 on page 10.



## User Relay Example Application

### *Connecting to an External Switchbox*

You can use an external switchbox connected to user relay on the 1757-SRM/B to determine which Logix controller you will attach to the other RS232 devices on the serial link. You must assemble an external switchbox to direct serial port devices to only one pair of redundant Logix controllers. Allen-Bradley does not supply the external switchbox with the modules.

Figure 3 illustrates an example connection scheme, with one single pole double throw switch for each RS232 signal. The external power supply output should not exceed the ratings of the external switchbox coil.

**TIP**

The same line voltage that provides power to Chassis A (to which user relay connections are made) should be used to provide input power to the external power supply.

Using the same line voltage insures that a line failure to both Chassis A and the external power supply will cause the external switchbox to switch to Chassis B when it de-energizes.

**WARNING**

Failure to use an appropriately rated switchbox may result in an explosion hazard. When installing this equipment in a Class I, Division 2 hazardous location, select an external switchbox that is appropriately certified for use in this environment.

**Figure 3 External Switchbox Connections to Logix Controller Serial Port**

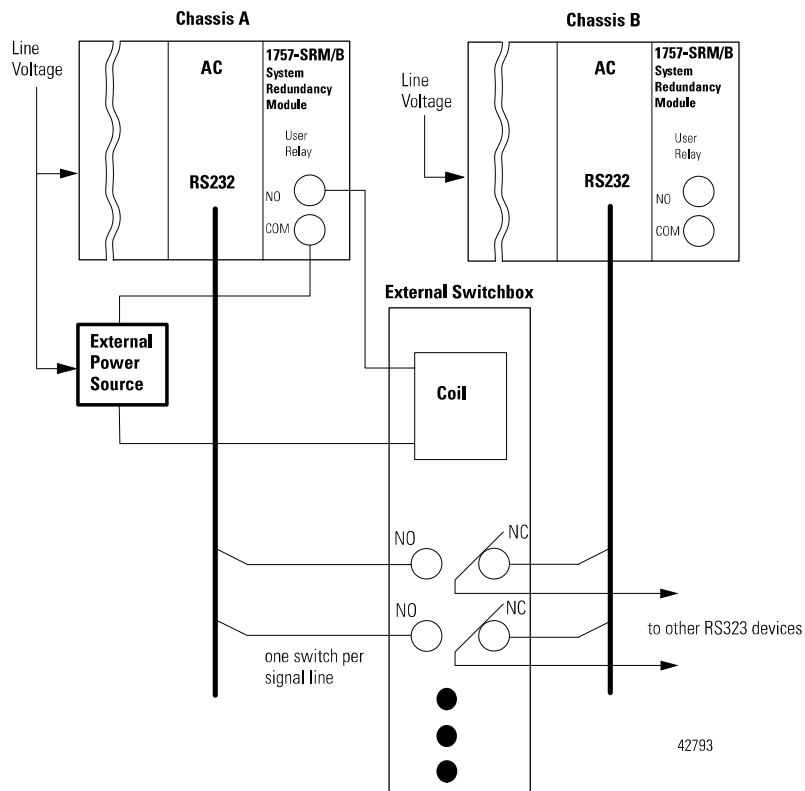

**ATTENTION**



Use the same line voltage input for the external power source as is used to supply power to Chassis A

## 1757-SRM Module LEDs and Display Codes

### Health LED

The right-most LED on the 1757-SRM face is the Health LED. Bi-color (red/green), the Health LED is labeled “OK” and indicates whether or not the module has power and operates correctly. The following table describes the Health LED status:

**Table 1 Health LED**

LED Status	Condition
off	<ul style="list-style-type: none"> <li>No power to 1757-SRM</li> </ul>
solid red	<ul style="list-style-type: none"> <li>Powerup self test</li> <li>1757-SRM critical failure</li> </ul>
flashing red	<ul style="list-style-type: none"> <li>1757-SRM NVS update</li> <li>1757-SRM non-critical failure</li> <li>1757-SRM configured improperly</li> </ul>
solid green	<ul style="list-style-type: none"> <li>1757-SRM O.K.</li> </ul>
flashing green	<ul style="list-style-type: none"> <li>1757-SRM O.K. but not communicating with other modules</li> </ul>

### Inter-1757-SRM Communication LED

The center LED on the 1757-SRM face state is the Inter-1757-SRM Comm LED. Bi-color (red/green), the Inter-1757-SRM COM LED is labeled “COM” and indicates activity on the inter-1757-SRM communications link. The following table describes the Inter-1757-SRM COM LED status.

**Table 2 Inter-1757-SRM COM LED**

LED Status	Condition
off	<ul style="list-style-type: none"> <li>No power</li> <li>No Inter-1757-SRM Comm activity</li> </ul>
red < 1 second	<ul style="list-style-type: none"> <li>Powerup with 1757-SRM establishing partner communication</li> </ul>
solid red	<ul style="list-style-type: none"> <li>Critical communication failure</li> </ul>
green flash	<ul style="list-style-type: none"> <li>Communication activity present (sampled every 250 ms)</li> </ul>

## Chassis State LED

The left-most LED on the 1757-SRM face is the Chassis State. Bi-color (red/green), the Chassis State LED indicates when the chassis is primary.

**Table 3 Chassis State LED**

LED Status	Condition
off	<ul style="list-style-type: none"> <li>No power</li> <li>1757-SRM chassis state is in secondary or failed state</li> </ul>
green < 1 second	<ul style="list-style-type: none"> <li>Powerup with partner 1757-SRM determining primary state</li> </ul>
solid green	<ul style="list-style-type: none"> <li>1757-SRM chassis state is in primary state</li> </ul>

## Character Display Codes

The table below outlines the codes displayed by the 4-character status display on the face of the 1757-SRM.

**Table 4 Character Display Codes**

Display	1757-SRM State
 (1)	Testing 4-character display at startup
Txxx <sup>(2)</sup>	1757-SRM self test at startup
????	Resolving initial state
DISQ	Disqualified secondary chassis
SYNC	Qualified secondary chassis
PRIM	Primary chassis
BOOT	Boot mode - awaiting further instructions
ERAS	Boot mode - erasing firmware
PROG	Boot mode - loading new firmware
Exxx <sup>(3)</sup>	Major fault situation
message <sup>(4)</sup>	The shifted message string will alternate with the error ID code

<sup>(1)</sup> all pixels on

<sup>(2)</sup> xxx represents a hexadecimal test identification number

<sup>(3)</sup> xxx represents an error or fault code, with the 2 least significant characters in decimal

<sup>(4)</sup> a shifted message string

## 1757-SRM Module Fault Codes and Display Messages

The 1757-SRM classifies Fault into four categories:

**Table 5 Categories of 1757-SRM Fault Codes**

Fault Type:	Description:
Minor Recoverable	<ul style="list-style-type: none"> <li>• The fault does not stop redundancy operations and provides you with a recovery mechanism.</li> <li>• The 1757-SRM may clear some minor recoverable faults on its own.</li> </ul>
Minor Non-Recoverable	<ul style="list-style-type: none"> <li>• The fault does not stop redundancy operations.</li> <li>• No recovery mechanism is available.</li> </ul>
Major Recoverable	<ul style="list-style-type: none"> <li>• The fault will impact redundancy operations, although the effect may not be immediate.</li> </ul> <p>For example, if the fault occurred in the Secondary 1757-SRM, it may not affect control until the Primary 1757-SRM fails,</p>
Major Non-Recoverable	<ul style="list-style-type: none"> <li>• The fault is a critical fault. Redundancy operations will cease.</li> <li>• A switchover may occur.</li> <li>• No recover mechanism is available.</li> <li>• The module may need to be replaced.</li> </ul>

All fault types are logged in the 1757-SRM's Event Log, which is stored in non-volatile memory. See the ControlLogix System Users Manual, publication 1756-UM001, for a description of how to access the 1757-SRM event log.

In addition to the Event Log, the 1757-SRM displays major faults on the module's 4 character status display in one of two ways; 2 to 4 character word abbreviations and alpha numeric codes. Table 6 describes the error messages, and tables 7 and 8 describe the alpha numeric codes.

**Table 6 2 to 4 Character Word Abbreviations**

If you see:				it means:	do this:
1st Word	2nd Word	3rd Word	4th Word	Error Description	Action
COMM	RSRC	ERR		Communication resource error	Reset SRM Module
OS	ERR			Operating system error	Replace SRM Module
COMM	RSRC	ERR	PRT1	Port1 Communication resource error on Backplane	Reset SRM Module and check rack
COMM	RSRC	ERR	PRT2	Port2 Communication resource error on Inter-SRM link	Reset SRM Module and check cable
WDOG	ERR			Watchdog time-out	Reset SRM Module
HDW	ERR			Hardware failure	Replace SRM Module
FMWR	ERR			Firmware error	Re-Flash firmware
CFG	LOG	ERR		Configuration log error	No Action
DUPL	RM			Duplicate SRM. This SRM is not in control.	Remove this SRM
RM	PWR	DOWN		SRM Power Down, Module detected a DC_Fail condition.	Check other modules in rack
COMM	ERR	PRT1		Port1 Communication error, Backplane communication	Check/Replace Rack
COMM	ERR	PRT2		Port2 Communication error, Inter-SRM communication link	Check/Replace SRM Cable
COMM	ERR			General Communication Error	No Action
EVNT	LOG	ERR		Event Log Error	No Action
WDOG	FAIL			Watchdog task failed its status check	Replace SRM

### Alpha Numeric Error Codes

The fault code is a 4 character alpha-numeric string. Valid characters are [0-9, A-Z], except [S,O]. The first character is always 'E'. Each firmware subsystem within the 1757-SRM is assigned a range of fault codes. Each subsystem assigns fault codes within its range. The format of the error code is as follows:

**Table 7 Alpha Numeric Error Codes E<sup>x</sup><sup>1</sup>x<sup>2</sup>x<sup>3</sup>**

Valid Character String	Indicates
<b>E</b>	error
<b>x<sup>1</sup></b>	the subsystem in which the error was detected
<b>x<sup>2</sup></b>	the subsystem function or group of functions in which the error was detected
<b>x<sup>3</sup></b>	enumerates the specific error

**Table 8 Fault Code Subsystem Assignment**

Range	Subsystem	Range	Subsystem
E 0 __	Backup Control Object	E A __	RM State Machine
E 1 __	OS Board Support Package	E B __	Event Log Device Driver
E 2 __	Chassis Profile Object	E C __	Object Communications
E 3 __	Coordinated System Time Object	E D __	Wall Clock Time Object
E 4 __	Device Object	E E __	Non-Maskable Interrupt Service Routine
E 5 __	Extended Log Object	E F __	Non-Volatile Storage Object
E 6 __	Event Log Object	E G __	RM Fault Handler
E 7 __	Backup Communications Object	E H __	Self Test Object
E 8 __	ICP Toolkit	E I __	Workstation Display Object
E 9 __	Indicator Device Driver	E J __	Industrial Control Platform Object
		E K __	RM Watchdog Manager

If you encounter one of these error codes, write the Exxx code down and contact Rockwell Automation Product Support using one of the methods described on page 20.

## Recovery Messages

For certain fault situations, specific recovery instructions will shift across the 4-character status display. The table below lists all recovery messages which originate within the SRM.





**SRM Display** is the string displayed on the SRM four character display. Up to four 4-character words will be shifted on the display.

**Table 9 Recovery Messages Logged by the 1757-SRM Module**

<b>SRM Display</b>	<b>Description</b>
RPLC MOD	Replace the module
RSET MOD	Reset the module
REMV MOD	Remove the module
SEAT MOD	Reinsert the module into the chassis



## Specifications

<b>Electrical</b>	backplane current	0.75 amp@3.3VDC 1.0 amp@5.1 VDC 0.090 amp@24 VDC
	power dissipation	9.6 watts
	thermal dissipation	9.6 watts
<b>Environmental</b> <sup>(1)</sup>	operating temperature	0 to 60 deg. C
	storage temperature	-40 to 85 deg. C
	relative humidity	5 to 95% without condensation
<b>Physical</b>	module type	redundancy
	module size	(ICP std, 2 slots wide)
	chassis location (recommended default)	slots 5-6 in 10-slot and 17-slot      slots 4-5 in 7-slot and 13-slot
	weight	0.452 kg
<b>Redundancy Cable Interfaces</b>	connectors	ST-type (fiber-optic)
	cable type	62.5/125 micron multi-mode fiber-optic cable
	channels	one (transmit and receive fiber)
	ground isolation	N/A (fiber-optic interface)
<b>Status Contact Cable Interface</b> 1757-SRM/B only	connectors	2-terminal Weidmuller #150191 mating connector supplied with redundancy module for use on user cable.
	cable type	shielded pair; conductor size range = AWG #14-22
	voltage/current ratings	30 v ac/dc maximum / 100 milliamps maximum
	channels	one
	ground isolation	1500 vac
<b>Agency Certifications</b> When product is marked:	 Listed Industrial Control Equipment  Certified Process Control Equipment Certified for use in Class I, Division 2, Groups A, B, C, D  Approved Class I, Division 2, Groups A, B, C, D  Marked for all applicable directives  Marked for all applicable acts N223	

<sup>(1)</sup> This product must be mounted within a suitable system enclosure to prevent personal injury resulting from accessibility to live parts. The interior of this enclosure must be accessible only by the use of a tool. This industrial control equipment is intended to operate in a Pollution Degree 2 environment, in overvoltage category II applications (as defined in IEC publication 664A), at altitudes up to 2000 meters without derating.

## **European Communities (EC) Directive Compliance**

If this product has the CE mark it is approved for installation within the European Union and EEA regions. It has been designed and tested to meet the following directives.

### **EMC Directive**

This product is tested to meet the Council Directive 89/336/EC Electromagnetic Compatibility (EMC) by applying the following standards, in whole or in part, documented in a technical construction file:

- EN 50081-2 EMC — Generic Emission Standard, Part 2 — Industrial Environment
- EN 50082-2 EMC — Generic Immunity Standard, Part 2 — Industrial Environment

This product is intended for use in an industrial environment.

### **Low Voltage Directive**

This product is tested to meet Council Directive 73/23/EEC Low Voltage, by applying the safety requirements of EN 61131-2 Programmable Controllers, Part 2 - Equipment Requirements and Tests. For specific information required by EN 61131-2, see the appropriate sections in this publication, as well as the Allen-Bradley publication Industrial Automation Wiring and Grounding Guidelines, publication 1770-4.1.

Open-style devices must be provided with environmental and safety protection by proper mounting in enclosures designed for specific application conditions. See NEMA Standards Publication 250 and IEC Publication 529 as applicable, for explanations of the degree of protection provided by different types of enclosures.

## Hazardous Location Approval

### The following information applies when operating this equipment in hazardous locations:

Products marked “CL I, DIV 2, GP A, B, C, D” are suitable for use in Class I Division 2 Groups A, B, C, D, Hazardous Locations and nonhazardous locations only. Each product is supplied with markings on the rating nameplate indicating the hazardous location temperature code. When combining products within a system, the most adverse temperature code (lowest “T” number) may be used to help determine the overall temperature code of the system. Combinations of equipment in your system are subject to investigation by the local authority that has jurisdiction at the time of installation.

<p><b>WARNING</b></p> 	<p><b>EXPLOSION HAZARD –</b></p> <ul style="list-style-type: none"> <li>• Do not disconnect equipment unless power has been removed or the area is known to be nonhazardous.</li> <li>• Do not disconnect connections to this equipment unless power has been removed or the area is known to be nonhazardous. Secure any external connections that mate to this equipment by using screws, sliding latches, threaded connectors, or other means provided with this product.</li> <li>• Substitution of components may impair suitability for Class I, Division 2.</li> <li>• If this product contains batteries, they must only be changed in an area known to be nonhazardous.</li> </ul>
--	---

### Informations sur l'utilisation de cet équipement en environnements dangereux:

Les produits marqués «CL I, DIV 2, GP A, B, C, D» ne conviennent qu'à une utilisation en environnements de Classe I Division 2 Groupes A, B, C, D dangereux et non dangereux. Chaque produit est livré avec des marquages sur sa plaque d'identification qui indiquent le code de température pour les environnements dangereux. Lorsque plusieurs produits sont combinés dans un système, le code de température le plus défavorable (code de température le plus faible) peut être utilisé pour déterminer le code de température global du système. Les combinaisons d'équipements dans le système sont sujettes à inspection par les autorités locales qualifiées au moment de l'installation.

<p><b>AVERTISSEMENT</b></p> 	<p><b>RISQUE D'EXPLOSION –</b></p> <ul style="list-style-type: none"> <li>• Couper le courant ou s'assurer que l'environnement est classé non dangereux avant de débrancher l'équipement.</li> <li>• Couper le courant ou s'assurer que l'environnement est classé non dangereux avant de débrancher les connecteurs. Fixer tous les connecteurs externes reliés à cet équipement à l'aide de vis, loquets coulissants, connecteurs filetés ou autres moyens fournis avec ce produit.</li> <li>• La substitution de composants peut rendre cet équipement inadapté à une utilisation en environnement de Classe I, Division 2.</li> <li>• S'assurer que l'environnement est classé non dangereux avant de changer les piles.</li> </ul>
---	---

## Rockwell Automation Support

Rockwell Automation offers support services worldwide, with over 75 sales/support offices, over 500 authorized distributors, and 260 authorized systems integrators located throughout the United States alone, plus Rockwell Automation representatives in every major country around the world. Contact your local Rockwell Automation representative for:

- sales and order support
- product technical training
- warranty support
- support service agreements

## Obtain Rockwell Automation Product Support

If you need to contact Rockwell Automation for technical assistance, try one of the following methods:

Type of technical support:	Access at:
Personalized Service	Call your local Rockwell Automation representative
Post-sales Technical Support	1,440,646,5800
Email your questions to	racleasktheexpert@ra.rockwell.com
Internet site	www.ab.com
Publications	www.theautomationbookstore.com

ProcessLogix, ControlLogix and Allen-Bradley are trademarks of Rockwell Automation.

### Reach us now at [www.rockwellautomation.com](http://www.rockwellautomation.com)

Wherever you need us, Rockwell Automation brings together leading brands in industrial automation including Allen-Bradley controls, Reliance Electric power transmission products, Dodge mechanical power transmission components, and Rockwell Software. Rockwell Automation's unique, flexible approach to helping customers achieve a competitive advantage is supported by thousands of authorized partners, distributors and system integrators around the world.

**Americas Headquarters**, 1201 South Second Street, Milwaukee, WI 53204, USA, Tel: (1) 414 382-2000, Fax: (1) 414 382-4444  
**European Headquarters SA/NV**, avenue Herrmann Detroix, 46, 1160 Brussels, Belgium, Tel: (32) 2 863 06 00, Fax: (32) 2 863 06 40  
**Asia Pacific Headquarters**, 27/F Citicorp Centre, 18 Whitfield Road, Causeway Bay, Hong Kong, Tel: (852) 2887 4788, Fax: (852) 2508 1846



Publication 1757-IN092B-EN-P - March 2001

Supersedes Publication 1757-IN092A-US-P - May 2000

PN 957464-47

© 2001 Rockwell International Corporation. Printed in the U.S.A.